



*Safe, Abundant Drinking Water.*

**City of Milwaukee  
Standard Suburban Plan Notes  
For Water Main Construction**

---

<b><u>DESCRIPTION</u></b>	<b><u>PAGE NUMBER</u></b>
1) Suburban Plan Specifications	2
2) Purchase of Materials	2
3) Installation Requirements	2
4) Line and Grade	2
5) Inspection	3
6) Material Testing	3
7) Winter Water Main Construction	3
8) Backflow Preventer	3
9) Hydrants and Valves	3
10) Water Service Requirements	4
11) Water Service Connections	4
12) Pipe Restraint	4
13) Water Quality Tests	4
14) Pressure Testing	5
15) Backfill and Bedding Material	5 & 6
16) Consolidation of Backfill and Aggregate Slurry Backfill	6
17) Minimum Cover & Clearance	7
18) Valve Box Base Adapter	8
19) Water Main Disinfection Process	9 & 10

### **1) Suburban Plan Specifications**

The City of Milwaukee “Water Main Installation Specifications” dated January 2, 1987, “Rules and Regulations Governing Water Service and Water Service Piping Specifications 2002”, and “Standards Suburban Notes” shall supersede all other applicable Water Main Installation specifications.

### **2) Purchase of Materials**

All materials required for the work, including pipe, pipe fittings, specials, valves and hydrants are to be furnished by the Contractor and the cost thereof included in the various unit price bid items.

All materials require inspection by the City of Milwaukee. See Section 5.

Material specifications for furnished materials may be found at <http://water.mpw.net/standardspecs.htm>. Local suppliers have copies of these specifications and are also available upon request from the City of Milwaukee Water Engineering Section.

### **3) Installation Requirements**

The water main may not be installed until all Right-of-Entry forms have been signed and received by the City of Milwaukee. The water main may not be connected to the Milwaukee Water Works Distribution System until all easements are executed or right-of-way openings have been recorded.

### **4) Line and Grade**

The water mains may not be installed until the City of Milwaukee Inspector is supplied with an approved plan with the cut data shown.

The perimeter of all proposed easements shall be staked out in conjunction with the new water main. The water main may not be installed until this has been completed.

All horizontal bends, vertical bends, reducers, connections, hydrants, valves, crosses, tees and breaks shall have straddler stakes. The contractor shall reproduce additional surveying markers as required.

Offset stakes are usually set every 25 feet, starting from the lowest elevation. In rural locations, a 50-foot distance is satisfactory. On water stakeouts, the cut is given to the centerline of the water main, for pipe 16” or smaller. Larger water mains are set to the flow line elevation.

Hydrants require a cut to the centerline and a cut or fill to the proposed new curb grade and to the hydrant flange. This is marked on the cut sheet and on the hydrant-offset stake. Cut sheets shall identify the facility being marked such as, hydrants, manholes, etc.

The gradient, or slope, of each section of water main should be checked and noted on the cut sheet. The contractor shall use this to set the laser, check grade points and lay pipe.

**5) Inspection**

Paragraph 3 of section 3.5.11 of the City of Milwaukee Water Main Installation Specifications, dated 1987, shall be revised to read:

The amount of per diem charge for inspection as referred to in section 2.5.11 shall be \$325.00. The contractor shall allow four working days notice for material inspection and for scheduling installation inspection prior to the start of construction. Contact Steve Brengosz at 414-708-2808 or Mark Scheller at 414-286-2427 for materials inspection and the City of Milwaukee's Construction Section at 414-286-2497 for installation inspection.

**6) Material Testing**

All material tests required on this contract shall be performed at a testing laboratory designated by the City of Milwaukee.

**7) Winter Water Main Construction**

No water main construction work shall be done between the days of December 15<sup>th</sup> and March 15<sup>th</sup> of the following year without permission from the City of Milwaukee Commissioner of Public Works or his representative.

**8) Backflow Preventer**

In any instance where water is used from a hydrant or other public water supply source, the contractor shall protect the public water supply by means of an appropriate backflow preventer.

Where the hose or outlet will be above the elevation of the water source, the contractor shall use a reduced pressure zone (rpz) backflow preventer. If a 3/4" or smaller hose supply is required a vacuum breaker-backflow preventer may be used. Where the hose and outlet will always be below the elevation of the water source an atmospheric vacuum breaker may be used. The backflow preventer shall be connected to the hydrant in compliance with section 2.8.12 of the City of Milwaukee Specifications and shall be self supporting imposing no load on the hydrant.

**9) Hydrants and Valves**

The contractor shall be responsible for tightening nuts and bolts on all valves and hydrants in this contract.

The contractor shall be responsible for installing the hydrant frangible coupling (flange) within 0.2' of the plan grade.

The contractor shall install hydrants with the nozzle section facing the street where practical.

The cost of modifying the hydrants shall be included in the unit price bid for installing hydrants.

## **10) Water Service Requirements**

Permits for water services shall be obtained before tapping the water main. Water services pipe size and location shall be established at the time of the permit application.

Curb stops shall be located three inches inside the right-of way or easement line.

Water services shall be installed within the extended building lines.

A Milwaukee plumbing permit is required if the branch piping extends beyond the branch valve.

Water service size may not be adequate if fire protection is required.

The water meter shall be located near the front wall of the building. The services shall run perpendicular to the water main and shall remain straight to the meter in the building.

## **11) Water Service Connections**

The contractor shall furnish and install, for all services, a service insulator (Ford Meter Box Co. Inc. SI-2, SI-4, SI-6, SI-7 or equal). Cost of furnishing and installing the service insulator shall be included in the unit bid price for the service. The service insulator shall be installed on the outlet (private property) side of the curb stop.

## **12) Pipe Restraint**

Pipe shall be restrained by means of concrete buttresses and anchors as shown on specification drawing no.'s 3 through 12 and 17. When adequate concrete buttressing is not possible, strapping and rodding as shown on drawing no.'s 13, 14, and 16 shall be installed for pipe restraint at 4" through 16" bends and offsets. Bell spigot restraints, as shown in drawing no. 15, shall be used only at the direction of the Commissioner of Public Works - City of Milwaukee.

- a) In conjunction with concrete restraints when the water main must be immediately restored to service, or
- b) Where other restraints cannot be used.

## **13) Water Quality Tests**

Section 5.18.1 of the specifications shall be revised to read:

Water from all new mains must successfully pass turbidity and bacterial tests performed by the City before the main is accepted for use.

**14) Pressure Testing**

The allowable leakage referred to in section 5.17.3 shall not exceed the number of gallons per hour as determined by the following formula:

$$GPH = \frac{S \times D \times \sqrt{P}}{148,000}$$

In which      *GPH* = gallons per hour  
                   *D* = nominal diameter of main in inches  
                   *S* = length of pipe tested in feet  
                   *P* = average pressure in pounds per square inch gauge during leakage test

**15) Backfill and Bedding Material**

The contractor shall have the option of using one of the following requirements for backfill and bedding on installations of 16” and smaller water mains.

Backfill

Material used to backfill water main trenches, as required in chapter 5.16.0 of the “Water Main Installations” of the City of Milwaukee, shall be one of the following options:

Option No. 1

Requirements for Crushed Aggregate Base Course, Grade 2, Section 304.2.6 of the “Standard Specification For Highway and Structure Construction” of the State of Wisconsin. The gradation requirements are as follows:

<u>Sieve Size</u>	<u>Crushed Gravel</u>	<u>Crushed Stone</u>
1 inch	100 %	100 %
3/8 inch	50 – 85 %	40 – 75 %
No. 4	35 – 65 %	25 – 60 %
No. 10	25 – 50 %	15 – 45 %
No. 40	10 – 30 %	–
No. 200	3 – 10 %	3 – 12 %

Option No. 2

<u>Sieve Size</u>	<u>1/4” Screenings</u>
1/2 inch	100 %
3/8 inch	–
No. 4	75 – 100 %
No. 8	–
No. 16	–
No. 30	–
No. 100	10 – 25 %

Option No. 3      Sieve Analysis, ASTM C 136

<u>Sieve Size</u>	<u>Percent Passing</u>	
2.5 inch	100.0 %	
2 inch	88.2 %	
1.5 inch	68.9 %	
1 inch	50.7 %	
3/4 inch	41.0 %	
1/2 inch	33.3 %	
3/8 inch	28.3 %	
No. 4	20.6 %	
No. 10	15.8 %	
No. 20	12.0 %	
No. 40	10.0 %	
No. 100	8.3 %	
No. 200	7.5 %	Percent Finer than No. 200 Sieve, ASTM C 117

Bedding

Option No. 1

Material used for bedding shall be per specification 4.6.0 of the “Water Main Installation Specifications” of the City of Milwaukee.

Option No. 2

<u>Sieve Size</u>	<u>1/4” Chips</u>
1/2 inch	100 %
3/8 inch	90 – 100 %
No. 4	–
No. 8	0 – 50 %
No. 16	–
No. 30	0 – 5 %

**16) Consolidation of Backfill and Aggregate Slurry Backfill**

The contractor shall consolidate all backfill by mechanical compaction per specification 2.6.14 (B) of the Standard Specifications for Sewer & Water Construction in Wisconsin. Per the specification, the initial compacted lift shall be two (2) feet. The specification language for subsequent lifts shall be revised to read, “Each subsequent compacted lift of material shall be one (1) foot”. Costs are to be included in the unit bid price for water main. Settling the trench by flooding the backfill will not be allowed.

Where specified on the plans, the contractor shall backfill with aggregate slurry per specification 8.43.8 of the Standard Specifications for Sewer & Water Construction in Wisconsin. A bid item for “Slurry Backfill”, measured by cubic yards, will be included on the water main construction plans. In addition, if the City of Milwaukee Construction supervisor determines that slurry backfill is required at a location not specified on the plans, and a bid item has not been included in the contract, the contractor shall be paid the “Fixed Price” extra for aggregate slurry backfill.

**17) Minimum Cover & Clearance**

The Department of Natural Resources Water & Sewer Separation Requirements (SEC.NR 811.67) shall apply as follows:

Horizontal - Water Mains shall be laid at least 8 feet horizontally from any existing or proposed sanitary or storm sewer.

Vertical - When water mains cross over sewers, at least 6" shall separate the bottom of the water main and the top of the sewer. When water mains cross under sewers, a minimum of 18" shall be maintained, between the top of the water main and the bottom of the sewer.

Joints - At crossings, water pipe shall be centered on the sewer so that joints will be as far from the sewer as possible. (per Milwaukee "Water Main Installation" Specifications Drawing No. 16)

Utilities - Maintain a minimum vertical clearance of 6" from the outside edge of the proposed water main or appurtenances to the outside edge of any existing or proposed utility. Maintain a horizontal distance of 3'-0" from the centerline of the proposed water main to the centerline of any existing or proposed utility. A minimum distance of 2'-0" of undisturbed earth between the outside edge of the proposed water main and the outside edge of any existing or proposed utility shall have priority.

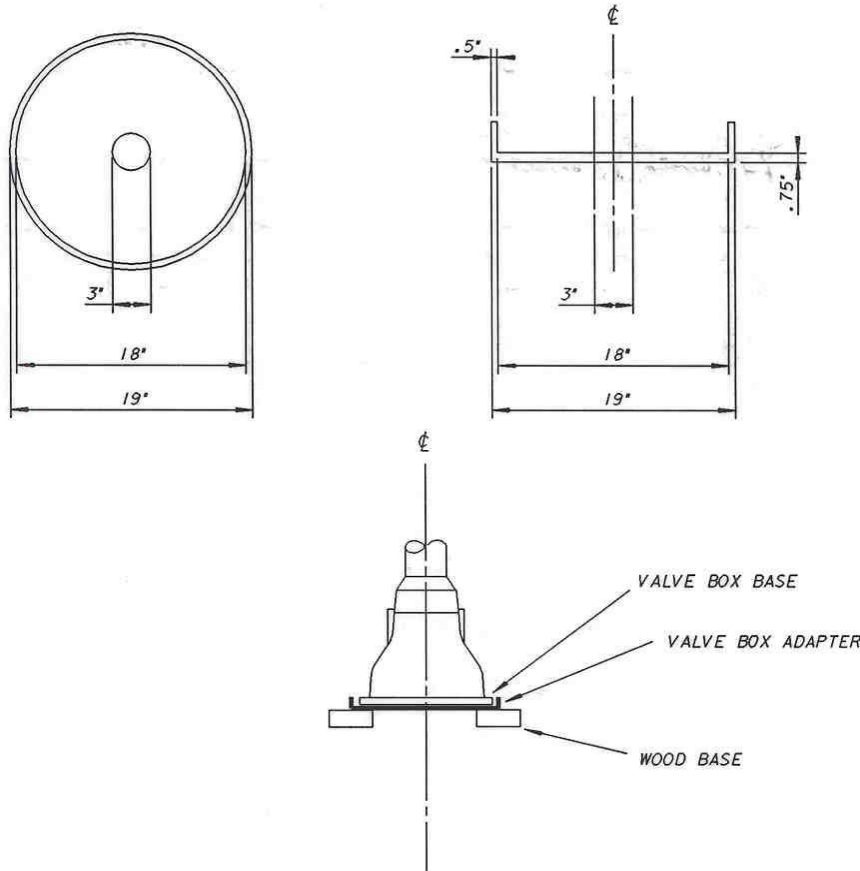

NOTES

- VALVE BOX BASE ADAPTER TO BE FURNISHED AND INSTALLED BY CONTRACTOR UNDER THE VALVE BOX BASE
- VALVE BOX BASE ADAPTER ADAPTOR II AS MANUFACTURED BY ADAPTORS INC. OR AN APPROVED EQUIVALENT
- THIS ADAPTER/VALVE BOX ASSEMBLY TO BE USED ONLY WITH GATE VALVES
- ADAPTER/VALVE BOX ASSEMBLY SHALL BE ADJUSTED OVER THE GATE VALVE JUST TO CLEAR THE OPERATING NUT.
- ADAPTER/VALVE BOX ASSEMBLY SHALL HAVE A SNUG FIT WITH THE BONNET ASSEMBLY.

NO.	BY	REVISION	DATE

<b>Water Engineering</b> Department of Public Works	
<b>VALVE BOX BASE ADAPTER</b>	
APPROVED  MAINS DESIGN ENGINEER	DATE 1-12-00
DESIGNED BY KSR	CHECKED BY SUM
DRAWN BY KSR	DATE 01-12-00
APPROVED  CHIEF DESIGN ENGINEER	DATE 01-12-00
<b>DRAWING NO. VBBA 1</b>	

## 19) Water Main Disinfection Process

This process shall supercede chapter 5.18.0 of the water main installation specifications dated January 2, 1987, entitled safe drinking water procedures and tests. The contractor shall be required to disinfect all proposed water mains in this contract using the following method:

1. The contractor shall supply and place calcium hypochlorite tablets in the water main as it is being installed. The placement of the tablets shall be per AWWA C651-99, Sec. 4.4.2. The tablets shall be attached to the top of the pipe with a food-grade adhesive (Permatex Form-A-Gasket No. 2 or Permatex Clear RTV silicone adhesive sealant or approved equal). The calcium hypochlorite tablets shall conform to AWWA C651-99, Sec. 4.1.3.
2. When installation is complete, the contractor shall fill the main with water at a rate to insure that the water within the main will flow at a velocity no greater than 1 ft/s (160gpm fill rate for an 8" water main). Precautions shall be taken to ensure that air pockets are eliminated. This water shall remain in the pipe for 24 hours.
3. Following the 24-hour waiting period, the construction section shall test for a chlorine residual of at least 5ppm at each end of the water main.
4. The contractor shall flush the super-chlorinated water out of the main. The contractor shall de-chlorinate the discharged water. The de-chlorinator shall be the "H2O Neutralizer" by Measurement Technologies, 704 – 228<sup>th</sup> Avenue NE, #601, Sammamish, WA 98074, (425) 868-8511, or equal.
5. Whether the chlorine residual was less than or greater than 5ppm, the construction section shall then pressure test the water main.
6. A) If the water main passed the pressure test and the chlorine residual was greater than 5ppm, then the contractor shall flush the water main for a period of 24 hours. Following the twenty-four hour flushing period, two samples shall be collected from the new main. One sample will be for a bacteriological test. The other sample will be tested for chlorine residual and turbidity. If the first samples are unsuccessful, another set of samples will be collected following an additional 24 hours of flushing. If the second set of samples is unsuccessful, re-chlorination will be required (See step 7). The contractor shall begin the wet connection process after obtaining successful samples.  
  
B) If the water main did not pass the pressure test, then the contractor shall make the necessary repairs and the water main shall be re-pressure tested. Following the successful pressure test, the contractor shall fill the water main. The construction section shall then chlorinate the water main by the continuous feed method per AWWA C651-99, Sec. 4.4.3. After successful chlorination (>10ppm chlorine residual), the contractor shall flush the super-chlorinated water out of the main and de-chlorinate the discharged water. The contractor shall then flush the main for a period of 24 hours. Following the twenty-four hour flushing period, two samples shall be collected from the new main. One sample will be for a bacteriological test. The other sample will be tested for chlorine residual and turbidity. If the first samples are unsuccessful, another set of samples will be collected following an additional 24 hours of flushing. If the second set of samples is unsuccessful, re-chlorination will be required (See Step 7). The contractor shall begin the wet connection process after obtaining successful samples.

- C) If the water main passed the pressure test but the chlorine residual was less than 5ppm, then the contractor shall fill the water main and the construction section shall chlorinate the water main by the continuous feed method per AWWA C651-99, Sec. 4.4.3. After successful chlorination, the contractor shall flush the super-chlorinated water out of the main and de-chlorinate the discharged water. The contractor shall then flush the main for a period of 24 hours. Following the twenty-four hour flushing period, two samples shall be collected from the new main. One sample will be for a bacteriological test. The other sample will be tested for chlorine residual and turbidity. If the first samples are unsuccessful, another set of samples will be collected following an additional 24 hours of flushing. If the second set of samples is unsuccessful, re-chlorination will be required (See Step 7). The contractor shall begin the wet connection process after obtaining a successful sample.
7. If acceptable bacteriological, chlorine residual, and turbidity samples cannot be obtained in two attempts, the construction section shall re-chlorinate the water main by the continuous feed method per AWWA C651-99, Sec. 4.4.3. After successful chlorination, the contractor shall flush the super-chlorinated water out of the main and de-chlorinate the discharged water. The contractor shall then flush the main for a period of 24 hours. Following the twenty-four hour flushing period, two samples shall be collected from the new main. One sample will be for a bacteriological test. The other sample will be tested for chlorine residual and turbidity. If the first samples are unsuccessful, another set of samples will be collected following an additional 24 hours of flushing. If the second set of samples is unsuccessful, the contractor will be required to excavate the water main to remedy the problem. If excavation is required, another successful pressure test will be needed prior to re-chlorination. The new water main connections to the distribution system cannot be made until successful samples are obtained.
  8. Note: the construction section shall take the samples to the Linnwood Plant testing lab. A Bac-T test shall be run on one of the samples. The other sample shall be tested for a chlorine residual of less than 2ppm and a turbidity ntu of less than 5.